

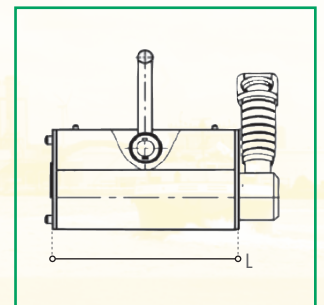

Hefmagneten / Magnetic lifters

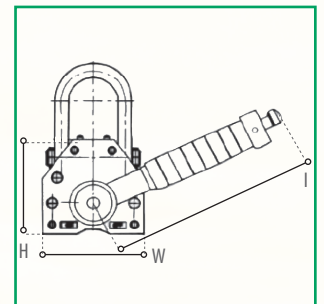

Eigenschappen

- » Geschikt voor het vasthouden en hijsen van staal materiaal.
- » Sterk magnetisch veld.
- » Met eenvoudig te bedienen hendel.
- » Veiligheidsfactor 1:3.5.

Features

- » Used to hold and release steel plates or iron blocks for lifting or handling operations.
- » With strong magnetic path produced by NdFeB permanent magnet.
- » On and off is controlled by turning the handle without extra power.

Specificaties / Specifications							
	DML - 1	DML - 3	DML - 6	DML - 10	DML - 20	DML - 30	DML - 60
Max. veilige belasting / WLL (kg)	100	300	600	1000	2000	3000	6000
Min. breeklast / Min. break load (kg)	350	1050	2100	3500	7000	10500	18000
Werktemperatuur / Operation temperature (°C)	< 80	< 80	< 80	< 80	< 80	< 80	< 80
Netto gewicht / Net. weight (kg)	3	10	24	50	125	220	398
Afmetingen / Dimensions							
	W		L		H		I
DML - 1	62		92		67		126
DML - 3	92		162		91		155
DML - 6	122		232		117		196
DML - 10	176		258		163		285
DML - 20	234		378		212		426
DML - 30	286		458		261		521
DML - 60	296		720		266		700